

EXTRACTOR



DCS MANUFACTURING PTY LTD

EXTRACTOR - High Pressure Jetting with Vacuum Recovery

Australian designed and manufactured high quality systems extensively employed throughout Australia by leading Contractors and Government Authorities.

Combination Jet/Vac System with Hydro-Excavation

The all-round system for cleaning and maintenance of storm water and sewer lines with hydro-excavation capability.

Controls	Remote and Manual
Debris Collector Body	8000 litre stainless steel
Unloading	50 degree tipping
Water Capacity	6000 litres
Water Pump	155 bar @269 lpm (2250 psi)
Vacuum Pump	24" Hg/2,300 m ³ /hr (1,400 CFM)
Hose Reel/Boom	Over head type with 200 degree rotation
Sewer Hose	Piranha 183 mtr x 1" ID
Hydro Pump	200 bar @ 30 lpm
Storage Compartment	Large canopy type with walk up staircase

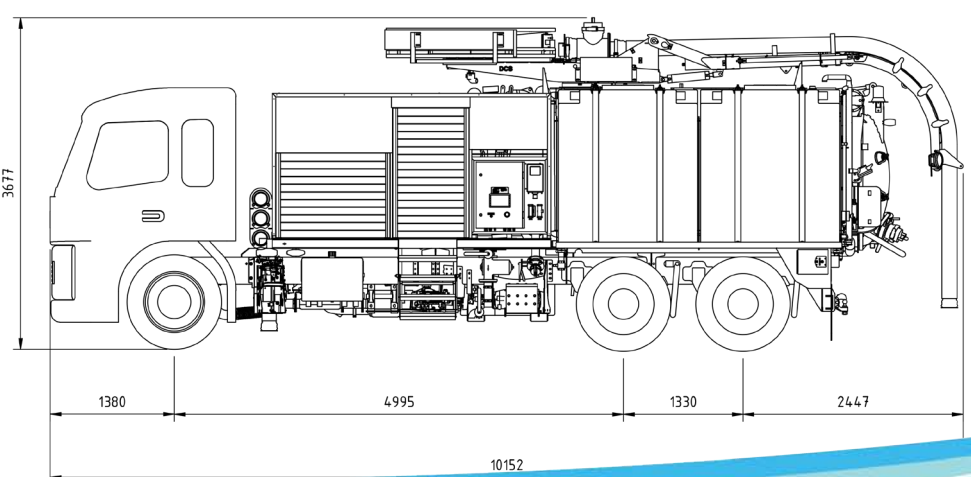

- Designed to comply to Australian Standards and Compliance Regulations
- Our systems offer reliability combined with high levels of safety
- Extensive spare parts back up and service support



DCS MANUFACTURING PTY LTD

33 Bazalgette Crescent, Dandenong South VIC 3175

p: +61 3 9775 1330

e. sales@dcsmanufacturing.com.au

www.dcsmanufacturing.com.au